

SPINCAT
DOWNHOLE TOOLS BY **STONEAGE**®

SPINCAT SC 125 ROTARY NOZZLE USER MANUAL



Hydropulsion 

PL 625 REV A
(03/2018)

TABLE OF CONTENTS

MANUFACTURER'S INFORMATION	3
SPECIFICATIONS.....	3
DESCRIPTION OF EQUIPMENT AND INTENDED USE	3
KEY FEATURES	3
SYSTEM ASSEMBLY - OVERVIEW	4
PRE-RIH CHECKLIST	5
LUBRICANT REPLACEMENT INSTRUCTIONS	6
HIGH PRESSURE SEAL REPLACEMENT	7
DISASSEMBLY	8
ASSEMBLY	10
TROUBLESHOOTING	12
TOOL STORAGE	12
REPLACEMENT PART WEAR INFORMATION	14
MAINTENANCE, PARTS, AND OVERHAUL KITS	15
TERMS AND CONDITIONS AND WARRANTY	16

StoneAge Inc.
466 S. Skylane Drive
Durango, CO 81303, USA
Phone: 970-259-2869
Toll Free: 866-795-1586
www.stoneagetools.com

Hydropulsion Ltd
154 Forest Avenue
Aberdeen AB15 4UN
United Kingdom
Phone: +44 (0) 1224 200125
info@hydropulsion.com
www.hydropulsion.com

This manual must be used in accordance with all applicable national laws. The manual shall be regarded as a part of the machine and shall be kept for reference until the final dismantling of the machine, as defined by applicable national law(s).

SPECIFICATIONS

Tool Family:	SpinCat
Tool Model:	SC-125
Pressure Range:	1-5k psi (70-340 bar)
Flow Range:	.5 to 1.5 bpm (21 to 63 gpm)
Flow Rating:	2.3 Cv
Rotation Speed:	10-50 rpm
Inlet Connection:	7/8" AMMT
PSI Loss (@ 1 bpm):	330 psi (23 bar)
Tension (pull):	Safe load to 8500 lbs (3856 kg)
Compression (set down):	Safe load to 12000 lbs (5443 kg)
Outside Diameter:	1.25 in. 32 mm
Overall Length:	8.3 in. 203 mm
Weight:	1.9 lbs .9 kg
Maximum Temperature:	390° F 200° C

JETTING

The SC-125 has two drilled head options for nominal flow rates of .5 to 1.5 bpm

DESCRIPTION OF EQUIPMENT AND INTENDED USE

The SC-125 provides well intervention teams with an advanced solution for 1 1/4" CT BHA's requiring a "slick" or Slimhole profile. Proven effective in wells with small ID restrictions, heavy scale deposition, and a history of entry challenges, the SC-125's smooth profile aids reaching target depths the first time then delivers powerful impact force and dwell time to enhance perf stimulation and clean-out objectives.

KEY FEATURES:

- Recessed head ensures rotation to continue when tool is against well bore wall and contributes to "slick" profile
- Constructed of hardened stainless steel for strength, durability & chemical resistance
- Effectively cuts scale in HCL acid clean-out jobs
- Drilled head sized for nominal flow rates of .5 to 1.5 bpm
- Viscous speed control
- Field serviceable

DESCRIPTION:

The Spincat is a self-rotating swivel designed for coil tubing well service. The powerful rotating jets cover a large area for efficient cleaning. Jet reaction force powers rotation of the head. An internal fluid speed control maintains rotation speeds of 10 to 50 rpm. The Spincat uses a synthetic silicone viscous fluid for lubrication. The fluid is available from StoneAge as part number BJ 048-S.

The tool has a straight flow-through design with a leak-free high pressure seal so pump power is not wasted. It has a 7/8" AMMT box inlet thread. The tool can be used at temperatures up to 200°C (392°F), and can be used with up to 30% HCL and Nitrogen injection. (Note: if used with HCL, flush tool with clean water after use.)

If the SpinCat™ will be used with high external borehole pressures, make certain that the body of the tool is completely full of lubricating fluid; air pockets are compressible and this could lead to oil seal failure and loss of lubrication.

The SpinCat™ can be used at operating pressures of 1000 to 5000 psi and flow rates of 0.5 to 1.5 bpm (21 to 63 gpm) with standard head porting.

FLOW RANGE	
PRESSURE	
1000-5000 PSI	.5 -1.5 BPM

The standard nozzle head has five drilled ports; one at 15 degrees forward, two at 45 degrees forward and two at 90 degrees to the axis of rotation. Customized heads are available with variable drilled patterns to concentrate the flow in a particular direction.

DANGER

Operations with this equipment can be potentially hazardous. Caution must be exercised prior to and during machine and water jet tool use. Please read and follow all of these instructions, in addition to the guidelines in the WJTA Recommended Practices handbook, available online at www.wjta.org. Deviating from safety instructions and recommended practices can lead to severe injury and/or death.

PRE-RIH CHECKLIST:

- After receipt on location, visually inspect the SpinCat™ to ensure no small debris has entered the tool. NOTE: The SpinCat™ package includes a briefcase size Pelican® case. We recommend keeping the SpinCat™ and spare set screws and other parts inside the case.
- Verify there is no oil leaking from the set screw or body. If the set screw is missing and oil has leaked out then perform the Lubrication procedure in this manual.
- Turn the SpinCat™ head by hand. It should rotate very smoothly but not spin freely. There should not be any stoppage or feeling of binding or catching internally.
- Ensure the Weep seal on the inlet nut is in place. The function of this seal is to prevent debris from plugging the vent holes. The vent hole's function is to vent internal pressure build-up should the high pressure (HP) tungsten impregnated seal fail or leak intermittently while reseating itself. If the wiper seal is lost or missing it can be replaced with a suitable size Viton® O-Ring as a temporary measure.
- The SpinCat™ is made of hardened stainless steel for long service life with strong acids, chemicals and solvents. We recommend you do not use pipe wrenches on the SpinCat™. Customers who have SpinCats™ 2-4 years old and are still in excellent condition, NEVER use pipe wrenches on their SpinCats™. Over time teeth cuts accumulate on the inlet nut, the body and head and “chew up” the tool. Eventually these parts have to be replaced unnecessarily. Some customers do not feel this is of significant importance and if replacement parts becomes necessary we can supply them.
- When function testing, watch for leakage along the body and behind the head. This indicates an improperly redressed tool. Also watch for leakage from around the Weep seal, the high pressure seal might leak during initial pressurization but should stop once enough pressure to achieve rotation has been reached. The only place water should be exiting the tool is through the nozzles. The head should rotate slowly and smoothly.
- If the head does not rotate during a function test but it rotates easily by hand, it could be the pump rate and pressure must be increased or the tool is simply “tight” or “cold,” or there is very heavy oil in the tool and it will loosen up in the hole, or the SpinCat™ may be jetted improperly. Check the SpinCat™ Jetting App. A simple but frequent problem in function tests is the test fluid does not contain viscosity reducer but the job requires it due to extremely high friction pressures.

LUBRICANT FILL INSTRUCTIONS

TOPPING OFF LUBRICANT:

The Spincat uses synthetic silicone viscous fluid for a lubricant. To top off the tool with lubricant, follow steps below. If the tool is being rebuilt or the seal replaced, the lubricant should be poured directly into the body around the shaft before the inlet nut is installed. To replace the high pressure seal, follow the steps on the right.

1. Remove the Port Plug Assembly (FT 026).
2. Remove the Inlet Nut.
3. Refill the Body with viscous fluid to 1/4" above the top of the upper Bearing.
4. Hold the Inlet nut at an angle with the Port Plug hole facing up. Thread Body onto Inlet Nut and tighten to 50 ft-lb.
5. Install Port Plug



HIGH PRESSURE SEAL REPLACEMENT

TO REPLACE THE HIGH PRESSURE SEAL:

1. Unscrew the Inlet Nut (SC125 002-AMMT) and remove the Port Plug Assembly (FT 026).
2. Remove the old Seat (SC168 011-C) and H.P. Seal (SC168 012-O).
3. Apply grease to and install new H.P. Seal into the shaft with the O-Ring groove end going in first. Do not press all the way into the shaft bore.
4. Install new Seat (SC168 011-C) with the chamfered face toward Inlet Nut. Press in just far enough so that the seat is captured in the shaft bore.
5. Fill the body with viscous fluid to 1/4" above the top of the upper bearing.
6. Hold the Inlet nut at an angle with the Port Plug hole facing up. Thread Body onto Inlet Nut and tighten to 50 ft-lb.
7. Install Port Plug with O-Ring.

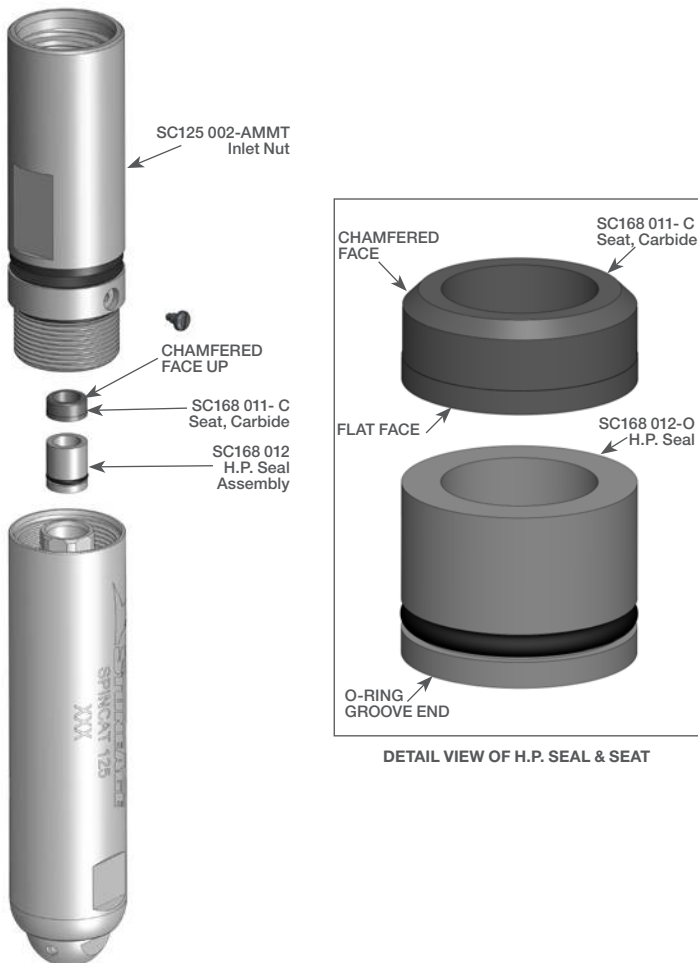

DISASSEMBLY

TO DISASSEMBLE THE SPINCAT SC-125:

1. Unscrew the Inlet Nut (SC125 002-AMMT) from the body.
2. Remove the Port Plug Assembly (FT 026) from the Nut.
3. Remove the Seat (SC168 011-C) and the H.P. Seal (SC168 012-O) from the bore of the shaft.
4. If the Shaft Seals (SC125 006) are damaged, remove them from the Nut using snap ring pliers.
5. If the O-Ring (SC125 008) is damaged, remove it from the Nut.
6. If the Weep Seal (SC125 021) is damaged, removed it from the Nut.

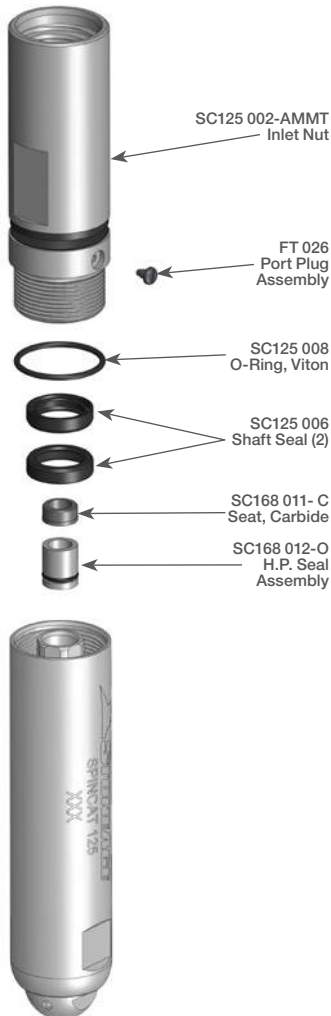

7. Unscrew the Inlet End Shaft (SC125 001.1) from the Outlet End Shaft/Head assembly and remove both from the Body.
8. Pull the Bearing (SC125 009) from the Inlet End Shaft.
9. If the O-Ring (SC125 016) is damaged, remove it from the bore of the Inlet End Shaft.
10. Remove the Thrust Bearing (SC125 007) from the Body.
11. If the Shaft Seals (SC125 006) are damaged, remove them from the Body.



ASSEMBLY

TO ASSEMBLE THE SPINCAT SC-125:

A StoneAge Seal Tool (SC125 050) is available to aid in installing the Seals in the Body and Nut.

1. Install Shaft Seals (SC125 007) into Body (SC125 003). Note direction of lip with spring on each Seal. Apply Armour-All to lips of seals.
2. Install Thrust Bearing (SC125 007) into Body. The end of the Bearing with the slightly larger bore (13mm) should go in facing down and towards the Seals as shown in detail.
3. Install Weep Seal (SC125 021) into deep groove of Inlet Nut (SC125 002-AMMT). Angled lip should be towards Port Plug hole.
4. Install O-Ring (SC125 008) onto relief groove behind threads of Inlet Nut (SC125 002-AMMT).
5. Install Shaft Seals (SC125 006) into Inlet Nut. Note direction of lip with spring on each Seal. Apply anti-seize to Inlet Nut threads. Apply Armour-All to lips of seals.

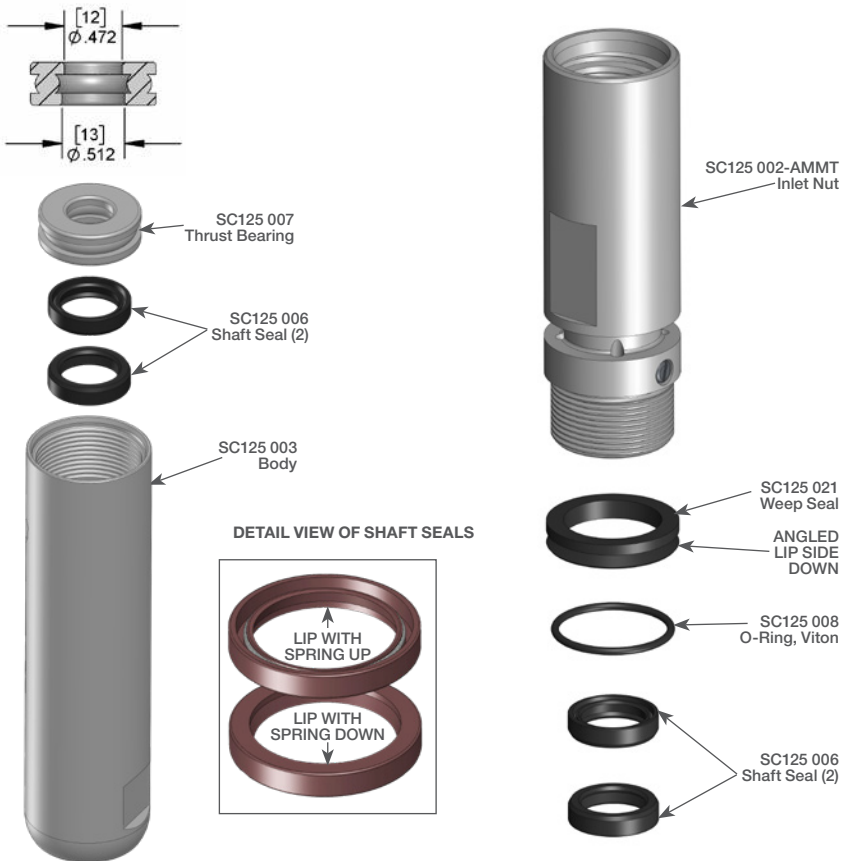

6. Thread the Head (SC125 043-X) onto Outlet End Shaft (SC125 001.2). Use Threadmate and fluorocarbon tape on the pipe threads.
NOTE: there is a 1/4" hex on the inside diameter of the Shaft for holding the Shaft when tightening. Tighten to 30 ft-lbs. Apply anti-seize to straight threads of the Shaft.
7. Install O-Ring (SC125 016) into internal groove in outgoing bore of the Inlet End Shaft (SC125 001.1). Apply grease to O-Ring.
8. Slide Head/Shaft assembly into the rounded end of the Body. Slide the Inlet End Shaft into the threaded end of the body and tighten shafts together to 30 ft-lbs.
9. Slide Bearing (SC125 009) into inlet end of Body.
10. Fill the tool with silicone lubricant to 1/4" above top of Bearing.
11. Install the H.P. Seal and Seat as shown in the Maintenance Section and thread the Body onto the Inlet Nut. Tighten to 50 ft-lbs.
12. Install Port Plug.

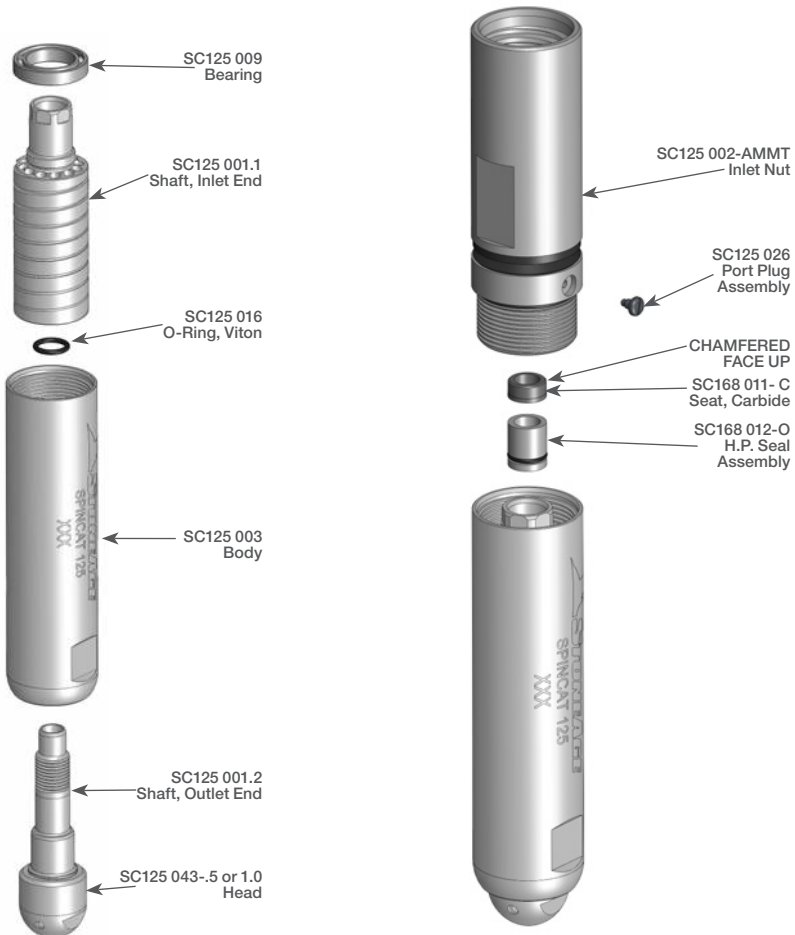

TROUBLESHOOTING

HIGH-PRESSURE SEAL LEAK:

- The high pressure seal may leak initially at lower pressures, but should pop closed as pressure is increased. A continuous leak at operating pressure from the weep holes indicates the need to replace the HP Seal and Seat. HP Seals wearing out too quickly can be an indication that the HP Seat is installed upside-down, or the tool is rotating too fast. If the tool is leaking, but not over rotating, the SC125 602 Seal Kit is required.

TOOL WILL NOT ROTATE:

- Check the nozzles for plugging or wear (nozzles have to be removed to check for obstructions).
- Check that the nozzle sizes are correct for the desired flow and that the desired flow matches the head flow range.
- Check that the nozzle sizes are installed in a balanced configuration.
- If the tool feels rough when manually rotating the head, this indicates internal damage and SC125 610 Overhaul Kit will be required.
- Check head by hand to make sure it rotates freely. If it does not rotate freely by hand, the tool needs to be disassembled and repaired. Research from field reports show that exceeding set-down weight may bend the headshaft ever so slightly and prevent rotation.

TOOL ROTATES TOO FAST:

- If the head rotates too fast, clean out old lubricating fluid and replace with fresh lubricant.
- If tool is showing heavy scuffing damage to body, we suggest that the customer install an available fluted body on the SpinCat™.

STORAGE

TOOL STORAGE:

The SpinCat™ should NOT be stored in a used condition with wellbore and pumped fluids possibly migrating into the lubricant chamber. Flush with fresh water and perform a seal redress after HCL, Xylene or Toluene chemical treatment jobs. Downhole tools, especially thru tubing tools tend to be stored upside down in tool racks with threaded stubs welded to rack base. Storing the SpinCat™ in this manner allows air to collect at the top of the lubricant chamber. We recommend the SpinCat™ be stored with inlet nut facing up to avoid this air pocket. The SpinCat™ may also be stored horizontally.

THIS PAGE LEFT INTENTIONALLY BLANK

REPLACEMENT PART WEAR INFORMATION

- BODY AND INLET NUT WEAR:**

Follow these wear dimension guidelines to determine when to replace parts.



SC125 003 Body Scuffing Wear

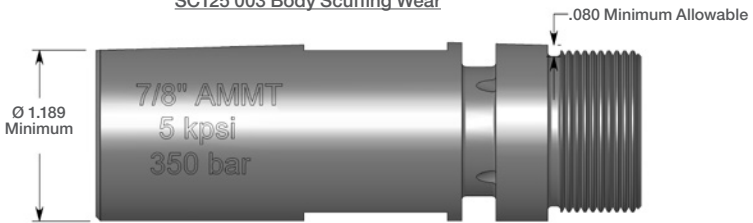

SC125 002 Inlet Nut Scuffing Wear

- SHAFT/HEAD WEAR:**

Follow these wear dimension guidelines to determine when to replace parts.

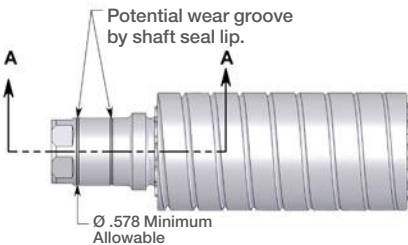

SC125 001.1 Shaft, Inlet Wear



SC125 001.2 Shaft, Outlet Wear

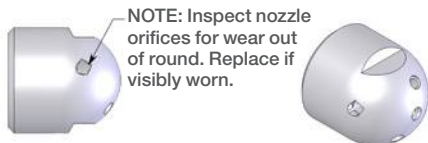
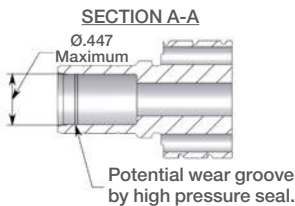

SC125 043 Head Wear

PARTS OVERVIEW

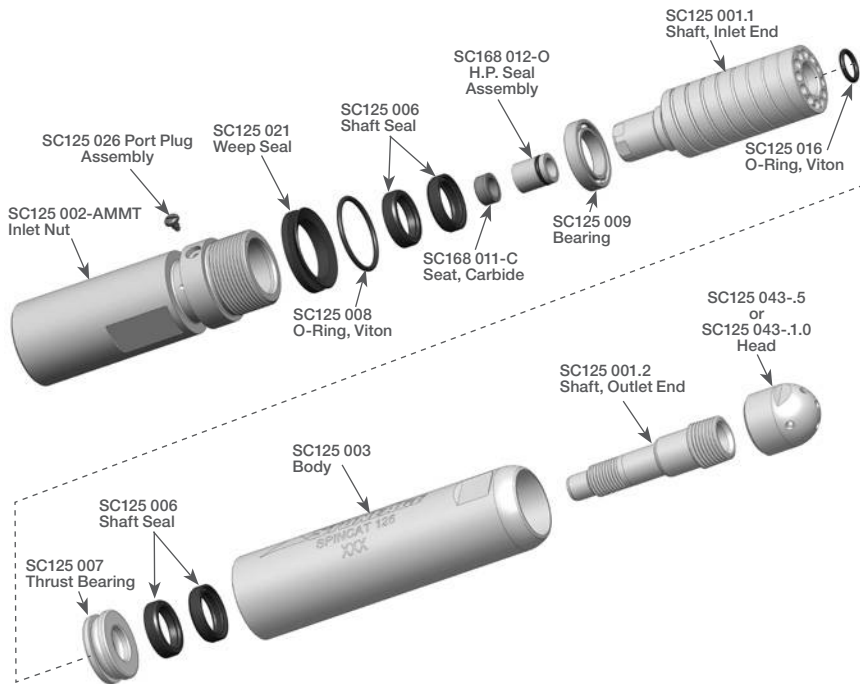

MAINTENANCE & OVERHAUL KIT PARTS

SC125 600 – LUBRICATION KIT

- 1 BJ 048 -S Viscous Fluid, Slow - 6oz
- 1 BJ 062-S Anti-seize, 2g
- 1 PL 625 SC-125 Manual Insert
- 1 SC125 026 Port Plug Assembly

SC125 602 -SEAL REDRESS KIT

- 1 BJ 048 -S Viscous Fluid, Slow - 6oz
- 1 BJ 062-S Anti-seize, 2g
- 1 PL 625 SC-125 Manual Insert
- 4 SC125 006 Shaft Seal
- 1 SC125 008 O-Ring, Viton
- 1 SC125 016 O-Ring
- 1 SC125 021 Weep Seal
- 1 SC125 026 Port Plug Assembly
- 1 SC168 011-C Carbide Seat
- 1 SC168 012-O HP/ High Temp Seal Assembly

SC125 610 - OVERHAUL KIT

- 1 BJ 048 -S Viscous Fluid, Slow - 6oz
- 1 BJ 062-S Anti-seize, 2g
- 1 GPT 022-250 Hex Key, 1/4", Standard L
- 1 PL 625 SC-125 Manual Insert
- 4 SC125 006 Shaft Seal
- 1 SC125 007 Thrust Bearing
- 1 SC125 008 O-Ring, Viton
- 1 SC125 009 Bearing
- 1 SC125 016 O-Ring
- 1 SC125 021 Weep Seal
- 1 SC125 026 Port Plug Assembly
- 1 SC125 050 Tool, Seal Installer
- 1 SC168 011-C Carbide Seat
- 1 SC168 012-O HP/ High Temp Seal Assembly

SC125 612 - TOOL KIT

- 1 SC125 050 Tool, Seal Installer
- 1 GPT 022-250 Hex Key, 1/4", Standard L

TERMS AND CONDITIONS AND WARRANTY INFORMATION

1. Acceptance of Terms and Conditions. Receipt of these Terms and Conditions of Sale ("Terms and Conditions") shall operate as the acceptance by StoneAge, Inc. ("Seller") of the order submitted by the purchaser ("Buyer"). Such acceptance is made expressly conditional on assent by Buyer to these Terms and Conditions. Such assent shall be deemed to have been given unless written notice of objection to any of these Terms and Conditions (including inconsistencies between Buyer's purchase order and this acceptance) is given by Buyer to Seller promptly on receipt hereof.

Seller desires to provide Buyer with prompt and efficient service. However, to individually negotiate the terms of each sales contract would substantially impair Seller's ability to provide such service. Accordingly, the product(s) furnished by Seller are sold only according to the terms and conditions stated herein and with the terms and conditions stated in any effective StoneAge Dealer Agreement or StoneAge Reseller Agreement, if applicable. Notwithstanding any terms and conditions on Buyer's order, Seller's performance of any contract is expressly made conditional on Buyer's agreement to these Terms and Conditions unless otherwise specifically agreed to in writing by Seller. In the absence of such agreement, commencement of performance, shipment and/or delivery shall be for Buyer's convenience only and shall not be deemed or construed to be an acceptance of Buyer's terms and conditions.

2. Payment/Prices. Unless other arrangements have been made in writing between Seller and Buyer, payment for the product(s) shall be made upon receipt of invoice. The prices shown on the face hereof are those currently in effect. Prices invoiced shall be per pricelist in effect at the time of shipment. Prices are subject to increase for inclusion of any and all taxes which are applicable and which arise from the sale, delivery or use of the product(s), and the collection of which Seller is or may be responsible to provide to any governmental authority, unless acceptable exemption certificates are provided by Buyer in accordance with applicable law. Buyer shall pay all charges for transportation and delivery and all excise, order, occupation, use or similar taxes, duties, levies, charges or surcharges applicable to the product(s) being purchased, whether now in effect or hereafter imposed by any governmental authority, foreign or domestic.

3. Warranty. SELLER MAKES NO WARRANTIES OR REPRESENTATIONS AS TO THE PERFORMANCE OF ANY PRODUCT EXCEPT AS SET FORTH IN THE STONEAGE LIMITED WARRANTY PROVIDED WITH THE PRODUCT.

4. Delivery. Seller is not obligated to make delivery by a specified date, but will always use its best efforts to make delivery within the time requested. The proposed shipment date is an estimate. Seller will notify Buyer promptly of any material delay and will specify the revised delivery date as soon as practicable. UNDER NO CIRCUMSTANCES SHALL SELLER HAVE ANY LIABILITY WHATSOEVER FOR LOSS OF USE OR FOR ANY DIRECT OR CONSEQUENTIAL DAMAGES RESULTING FROM DELAY REGARDLESS OF THE REASON(S).

All product(s) will be shipped F.O.B. point of origin, unless specifically agreed otherwise, and Buyer shall pay all shipping costs and insurance costs from that point. Seller, in its sole discretion, will determine and arrange the means and manner of transportation of the product(s). Buyer shall bear all risk of loss commencing with the shipment or distribution of the product(s) from Seller's warehouse. Order shortages or errors must be reported within fifteen (15) business days from receipt of shipment to secure adjustment. No product(s) may be returned without securing written approval from Seller.

5. Modification. These Terms and Conditions are intended by Seller and Buyer to constitute a final, complete and exclusive expression of agreement relating to the subject matter hereof and cannot be supplemented or amended without Seller's prior written approval.

6. Omission. Seller's waiver of any breach or Seller's failure to enforce any of these Terms and Conditions at any time, shall not in any way affect, limit or waive Seller's right thereafter to enforce and compel strict compliance with every term and condition hereof.

7. Severability. If any provision of these Terms and Conditions is held to be invalid or unenforceable, such invalidity or unenforceability shall not affect the validity or enforceability of the other portions hereof.

TERMS AND CONDITIONS AND WARRANTY INFORMATION

8. Disputes. Seller and Buyer shall attempt in good faith to promptly resolve any dispute arising under these Terms and Conditions by negotiations between representatives who have authority to settle the controversy. If unsuccessful, Seller and Buyer shall further attempt in good faith to settle the dispute by nonbinding third-party mediation, with fees and expenses of such mediation apportioned equally to each side. Any dispute not so resolved by negotiation or mediation may then be submitted to a court of competent jurisdiction in accordance with the terms hereof. These procedures are the exclusive procedures for the resolution of all such disputes between the Seller and Buyer.

9. Governing Law. All sales, agreements for sale, offers to sell, proposals, acknowledgments and contracts of sale, including, but not limited to, purchase orders accepted by Seller, shall be considered a contract under the laws of the State of Colorado and the rights and duties of all persons, and the construction and effect of all provisions hereof shall be governed by and construed according to the laws of such state.

WARRANTY:

Warranties set forth herein extend only to End-Users, meaning customers acquiring, or that have previously acquired, a product manufactured by StoneAge ("Product") for their own use and not for resale, either directly from StoneAge Inc. ("StoneAge") or from a StoneAge Authorized Dealer or Reseller ("Dealer"). No warranty of any kind or nature is made by StoneAge beyond those expressly stated herein.

1. LIMITED WARRANTY PERIOD. Subject to the limitations and conditions hereinafter set forth, StoneAge warrants its Product to be free from defects in workmanship and material for a period of one (1) year from the date of purchase by the End-User, provided that the end of the limited warranty period shall not be later than eighteen (18) months from the date of shipment of the Product to the Dealer or the End-User by StoneAge ("Limited Warranty Period"). All replacement parts which are furnished under this Limited Warranty and properly installed shall be warranted to the same extent as the original Product under this Limited Warranty if, and only if, the original parts were found to be defective within the original Limited Warranty Period covering the original Product. Replacement parts are warranted for the remainder of the original Limited Warranty Period. This Limited Warranty does not cover any component part of any Product not manufactured by StoneAge. Any such component part is subject exclusively to the component manufacturer's warranty terms and conditions.

10. Jurisdiction and Venue. Seller and Buyer agree that the state or federal courts located within the City and County of Denver, Colorado shall have sole and exclusive jurisdiction over any litigation concerning any dispute arising under these Terms and Conditions not otherwise resolved pursuant to Section 9 as well as any alleged defects of any Products or damages sustained as a result of such alleged defects. Seller and Buyer further agree that should any litigation be commenced in connection with such a dispute, it shall only be commenced in such courts. Seller and Buyer agree to the exclusive jurisdiction of such courts and neither will raise any objection to the jurisdiction and venue of such courts, including as a result of inconvenience.

11. Attorney's Fees. If any litigation is commenced between Seller and Buyer, or their personal representatives, concerning any provision hereof, the party prevailing in the litigation shall be entitled, in addition to such other relief that is granted, to a reasonable sum as and for their attorneys' fees and costs in such litigation or mediation.

2. LIMITED WARRANTY COVERAGE. StoneAge's sole obligation under this Limited Warranty shall be, at StoneAge's option and upon StoneAge's inspection, to repair, replace or issue a credit for any Product which is determined by StoneAge to be defective in material or workmanship. StoneAge reserves the right to examine the alleged defective Product to determine whether this Limited Warranty is applicable, and final determination of limited warranty coverage lies solely with StoneAge. No statement or recommendation made by a StoneAge representative, Dealer or agent to End-User shall constitute a warranty by StoneAge or a waiver or modification to any of the provisions hereof or create any liability for StoneAge.

3. WARRANTY SERVICE PROVIDERS. Service and repair of the Product is to be performed only by StoneAge authorized service representatives, including Dealers who are authorized repair centers, with StoneAge approved parts. Information about StoneAge authorized service representatives can be obtained through the StoneAge website at www.stoneagetools.com/service. Unauthorized service, repair or modification of the Product or use of parts not approved by StoneAge will void this Limited Warranty. StoneAge reserves the right to change or improve the material and design of the Product at any time without notice to End-User, and StoneAge is not obligated to make the same improvements during warranty service to any Product previously manufactured.

TERMS AND CONDITIONS AND WARRANTY INFORMATION

4. WARRANTY EXCLUSIONS. This Limited Warranty does not cover, and StoneAge shall not be responsible for the following, or damage caused by the following: (1) any Product that has been altered or modified in any way not approved by StoneAge in advance in writing; (2) any Product that has been operated under more severe conditions or beyond the rated capacity specified for that Product; (3) depreciation or damage caused by normal wear and tear, failure to follow operation or installation instructions, misuse, negligence or lack of proper protection during storage; (4) exposure to fire, moisture, water intrusion, electrical stress, insects, explosions, extraordinary weather and/or environmental conditions including, but not limited to lightning, natural disasters, storms, windstorms, hail, earthquakes, acts of God or any other force majeure event; (5) damage to any Product caused by any attempt to repair, replace, or service the Product by persons other than StoneAge authorized service representatives; (6) costs of normal maintenance parts and services; (7) damage sustained during unloading, shipment or transit of the Product; or (8) failure to perform the recommended periodic maintenance procedures listed in the Operator's Manual accompanying the Product.

5. REQUIRED WARRANTY PROCEDURES. To be eligible for warranty service, the End-User must: (1) report the Product defect to the entity where the Product was purchased (i.e. StoneAge or the Dealer) within the Limited Warranty Period specified in this Limited Warranty; (2) submit the original invoice to establish ownership and date of purchase; and (3) make the Product available to a StoneAge authorized service representative for inspection to determine eligibility for coverage under this Limited Warranty. This Limited Warranty shall not extend to any person or entity who fails to provide proof of original purchase from StoneAge or a Dealer. No Product may be returned for credit or adjustment without prior written permission from StoneAge.

6. DISCLAIMER OF IMPLIED WARRANTIES AND OTHER REMEDIES. EXCEPT AS EXPRESSLY STATED HEREIN (AND TO THE FULLEST EXTENT ALLOWED UNDER APPLICABLE LAW), STONEAGE HEREBY DISCLAIMS ALL OTHER WARRANTIES, EXPRESS OR IMPLIED, INCLUDING WITHOUT LIMITATION ALL IMPLIED WARRANTIES OF MERCHANTABILITY OR FITNESS FOR A PARTICULAR PURPOSE, AND ANY AND ALL WARRANTIES, REPRESENTATIONS OR PROMISES AS TO THE QUALITY, PERFORMANCE OR FREEDOM FROM DEFECT OF THE PRODUCT COVERED BY THIS LIMITED WARRANTY. STONEAGE FURTHER DISCLAIMS ALL IMPLIED INDEMNITIES.

7. LIMITATION OF LIABILITY. End-User specifically acknowledges that the Product may be operated at high speeds and/or pressures, and that as such it may be inherently dangerous if not used correctly. End-User shall familiarize itself with all operation materials provided by StoneAge and shall at all times use and require its agents, employees and contractors to use all necessary and appropriate safety devices, guards and proper safe operating procedures. In no event shall StoneAge be responsible for any injuries to persons or property caused directly or indirectly by the operation of the Product if End-User or any agent, employee, or contractor of End-User: (1) fails to use all necessary and appropriate safety devices, guards and proper safe operating procedures; (2) fails to maintain in good working order such safety devices and guards; (3) alters or modifies the Product in any way not approved by StoneAge in advance in writing; (4) allows the Product to be operated under more severe conditions or beyond the rated capacity specified for the Product; or (5) otherwise negligently operates the Product. End-User shall indemnify and hold StoneAge harmless from any and all liability or obligation incurred by or against StoneAge, including costs and attorneys' fees, to or by any person so injured.

TO THE FULL EXTENT ALLOWED BY APPLICABLE LAW, STONEAGE SHALL NOT BE LIABLE FOR ANY INDIRECT, SPECIAL, INCIDENTAL, CONSEQUENTIAL, OR PUNITIVE DAMAGES (INCLUDING WITHOUT LIMITATION, LOSS OF PROFITS, LOSS OF GOODWILL, DIMINUTION OF VALUE, WORK STOPPAGE, INTERRUPTION OF BUSINESS, RENTAL OF SUBSTITUTE PRODUCT, OR OTHER COMMERCIAL LOSS EVEN TO THE EXTENT SUCH DAMAGES WOULD CONSTITUTE DIRECT DAMAGES), WITH RESPECT TO THE COVERED STONEAGE PRODUCT, OR OTHERWISE IN CONNECTION WITH THIS LIMITED WARRANTY, REGARDLESS OF WHETHER STONEAGE HAS BEEN ADVISED OF THE POSSIBILITY OF SUCH DAMAGES.

IT IS UNDERSTOOD THAT STONEAGE'S LIABILITY, WHETHER IN CONTRACT, IN TORT, UNDER ANY WARRANTY, IN NEGLIGENCE, OR OTHERWISE SHALL NOT EXCEED THE AMOUNT OF THE PURCHASE PRICE PAID BY THE END-USER FOR THE PRODUCT. STONEAGE'S MAXIMUM LIABILITY SHALL NOT EXCEED, AND END-USER'S REMEDY IS LIMITED TO EITHER (1) REPAIR OR REPLACEMENT OF THE DEFECTIVE WORKMANSHIP OR MATERIAL OR, AT STONEAGE'S OPTION, (2) REFUND OF THE PURCHASE PRICE, OR (3) ISSUANCE OF A CREDIT FOR THE PURCHASE PRICE, AND SUCH REMEDIES SHALL BE END-USER'S ENTIRE AND EXCLUSIVE REMEDY.

TERMS AND CONDITIONS AND WARRANTY INFORMATION

YOU, THE END-USER, UNDERSTAND AND EXPRESSLY AGREE THAT THE FOREGOING LIMITATIONS ON LIABILITY ARE PART OF THE CONSIDERATION IN THE PRICE OF THE STONEAGE PRODUCT YOU PURCHASED.

Some jurisdictions do not allow the limitation or exclusion of liability for certain damages, so the above limitations and exclusions may not apply to you. This Limited Warranty gives you specific legal rights, and you may also have other rights which vary from jurisdiction to jurisdiction. If any provisions of this Limited Warranty is held to be invalid or unenforceable, such invalidity or unenforceability shall not affect the validity or enforceability of the other portions hereof.



1-866-795-1586 • www.STONEAGETOOLS.com
© 2015 StoneAge, Inc. All Rights Reserved



+44 (0) 1224 200125 • www.hydropulsion.com
info@hydropulsion.com